

PLEASE SIGN

CONTRACTOR TO VERIFY:

(A) _____ OVERALL LADDER HEIGHT
 (B) _____ F.F. TO TOP OF PARAPET
 (C) _____ LADDER WIDTH
 (D) _____ WALL TO Q OF LADDER

APPROVED BY: _____
 DATE: _____

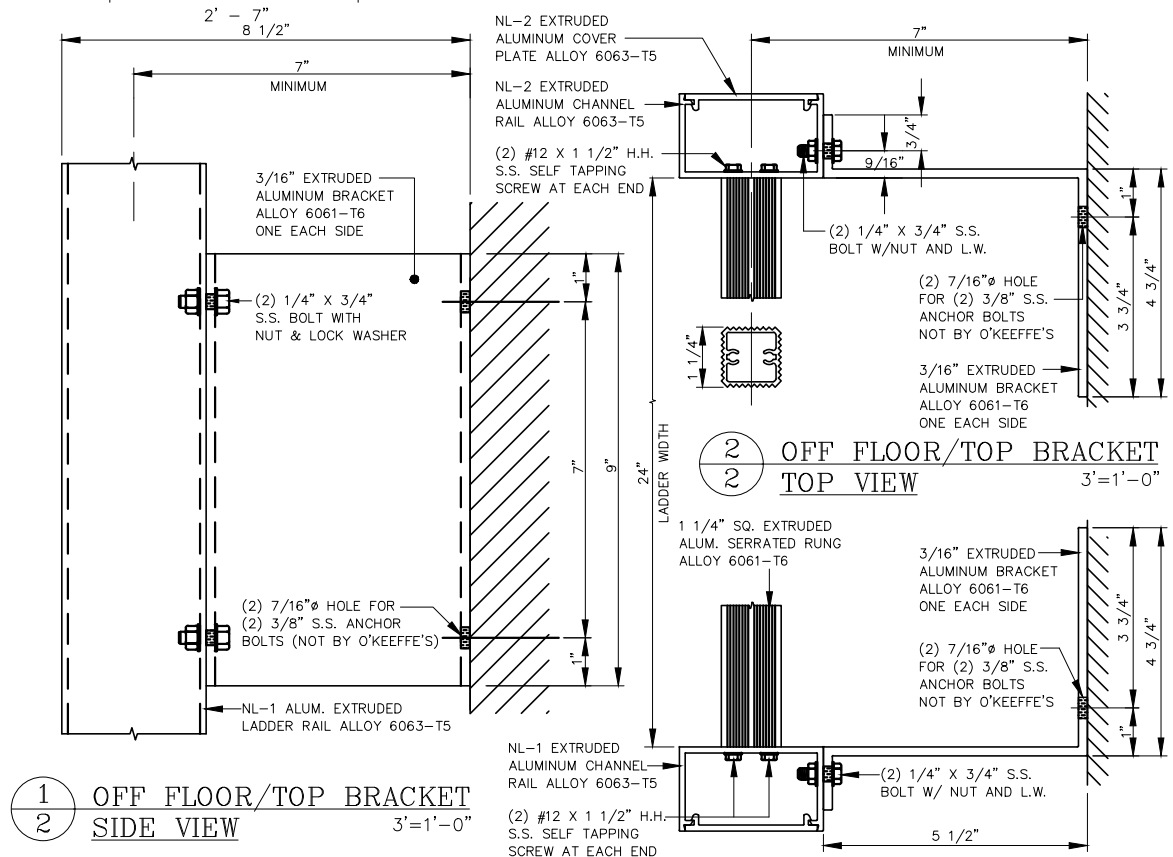

O'KEEFFE'S, INC.

100 N. HILL DR. SUITE 12
BRISBANE, CA 94005-1010

TEL: (415) 824-4900
FAX: (415) 824-5900

HEAVY DUTY TUBULAR RAIL ALUMINUM CAGE LADDER
LOW PARAPET WITH WALK THROUGH RAIL EXTENSIONS MODEL 534

_____ QUANTITY	<input type="checkbox"/> ALTERNATE BOTTOM SUPPORT
<input type="checkbox"/> SECURITY DOOR	<input type="checkbox"/> MILL FINISH
<input type="checkbox"/> INTERMEDIATE BRACKET	<input type="checkbox"/> POWDER COATING
	<input type="checkbox"/> BRONZE ANODIZED
	<input type="checkbox"/> CLEAR ANODIZED

SALE NO.
DRAWN :
DATE :
SHEET : _____ OF _____