

CONTRACTOR TO VERIFY:

- (A1) _____ OVERALL LADDER HEIGHT
- (A2) _____ LADDER HEIGHT
- (B) _____ LADDER ANGLE
- (C) _____ LADDER WIDTH
- (D) _____ PLATFORM DIMENSION
- (E) _____ LADDER RETURN HEIGHT

NOTE:

- * ALL BOLTS/FASTENERS NECESSARY TO ANCHOR LADDER BY OTHERS
- * PIPE HANDRAIL TO BE FIELD ASSEMBLED

APPROVED BY: _____

DATE _____

24" (C)
LADDER WIDTH

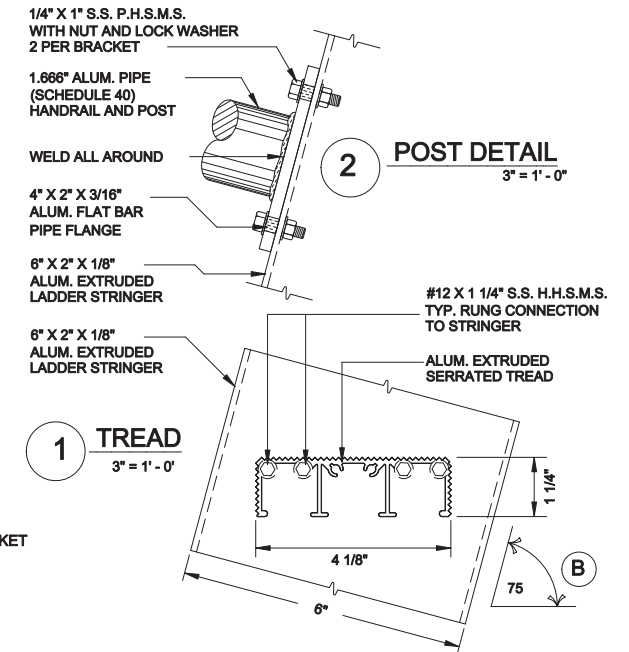
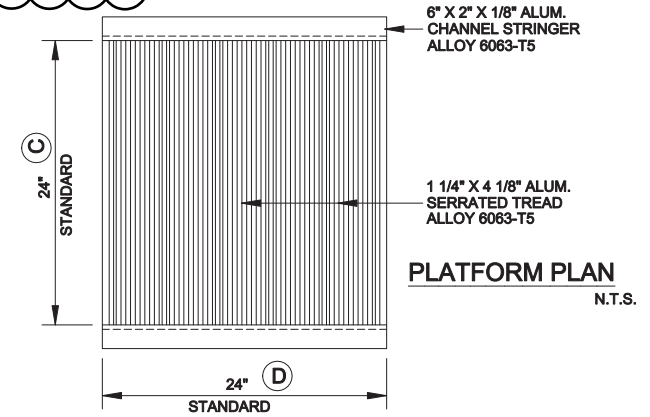
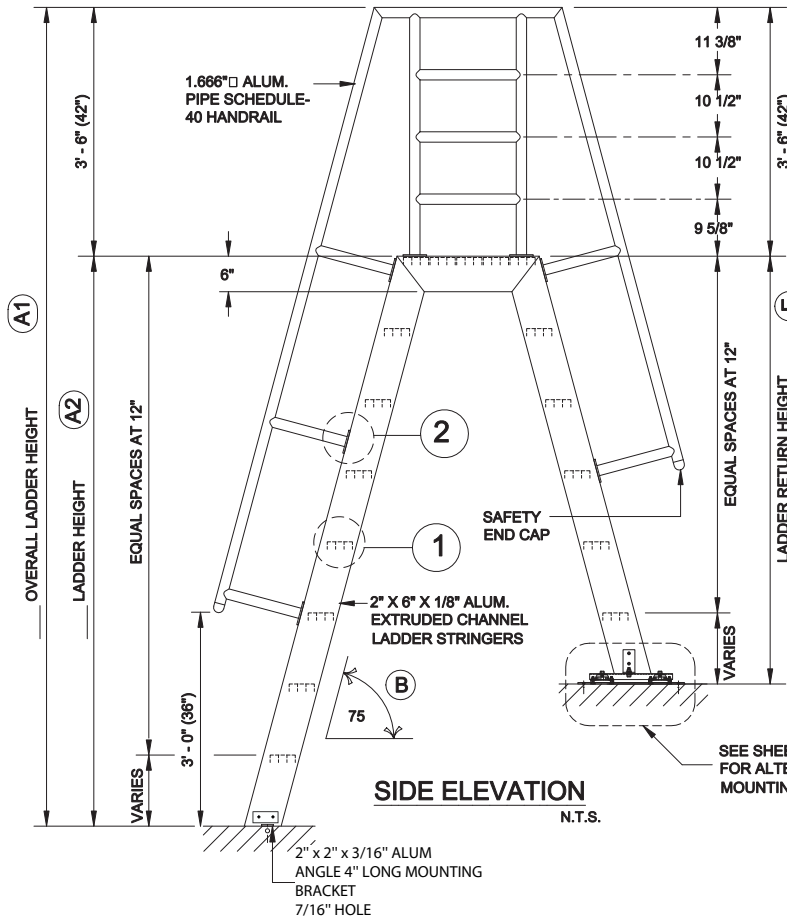
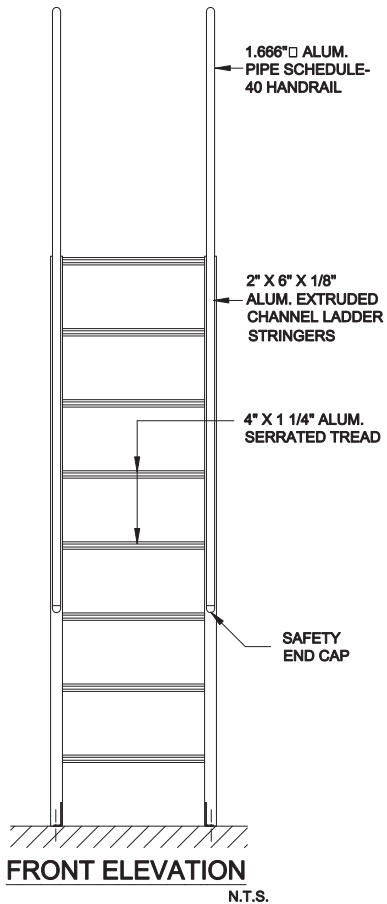

O'KEEFFE'S, INC.

100 N HILL DR, STE 12
BRISBANE, CA 94005

TEL: (888) 653-3333
FAX: (888) 653-4444 www.okeeffes.com

**ALUMINUM SHIPS LADDER WITH PLATFORM & TREAD
MODEL 522 WITH 75° ANGLE**

QUANTITY _____

- MILL FINISH
- BRONZE ANODIZED
- POWDER COATING
- CLEAR ANODIZED

SALE NO. _____

DRAWN: _____

DATE: _____

SHEET: _____ OF _____