

FRONT ELEVATION
N.T.S.

APPROVED BY: _____
DATE _____

CONTRACTOR TO VERIFY:

(A) _____ LADDER HEIGHT
(B) _____ LADDER ANGLE
(C) _____ LADDER WIDTH
(D) _____ ROOFHATCH BASE HEIGHT

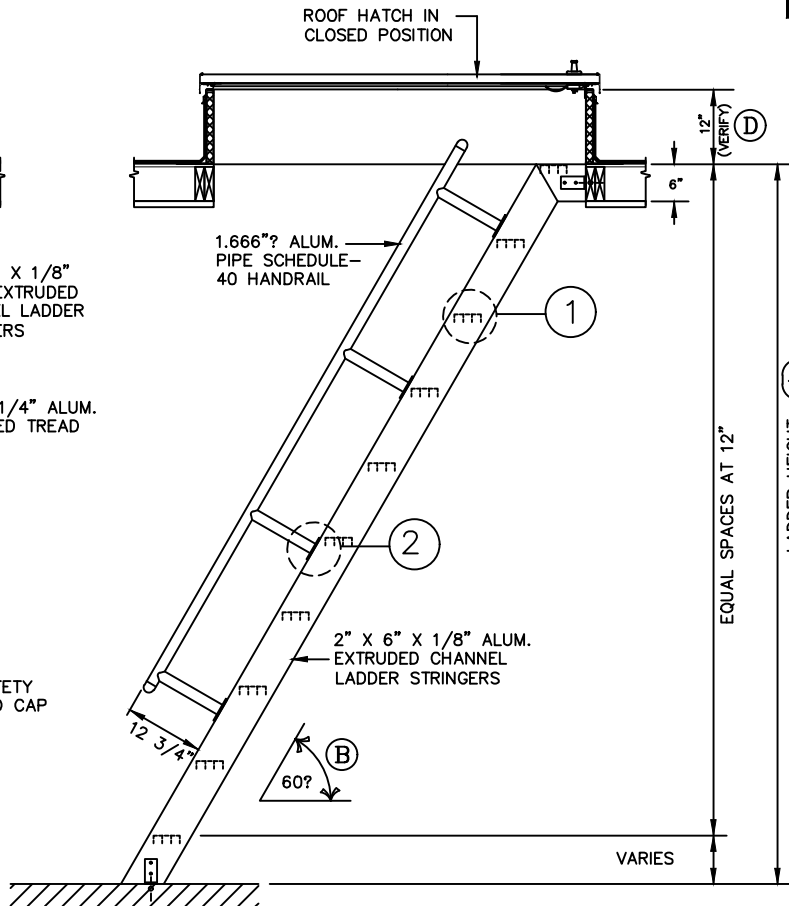

SIDE ELEVATION
N.T.S.

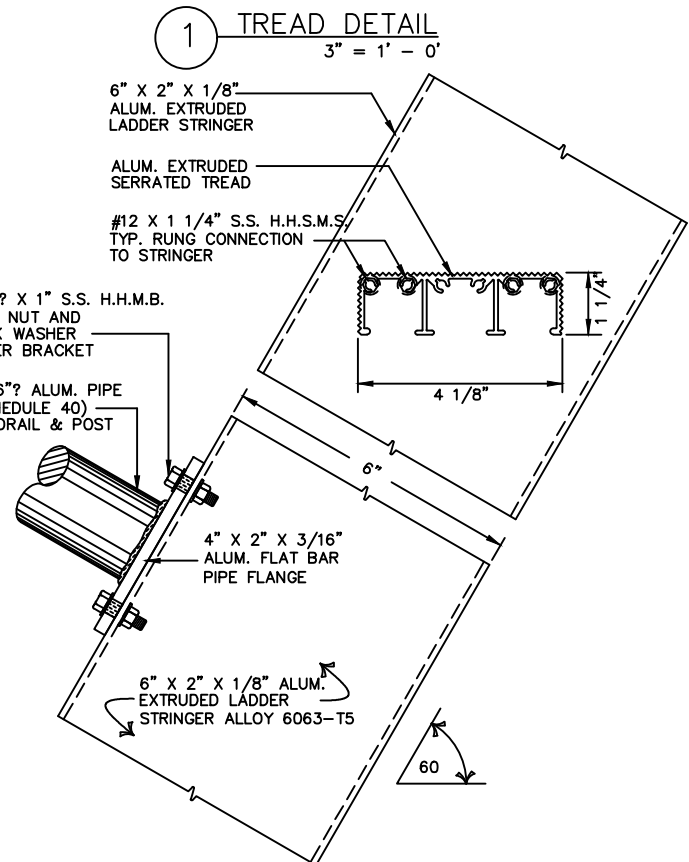

(2) **POST DETAIL**
3" = 1' - 0"



O'KEEFFE'S, INC.

100 N HILL DR, STE 12 TEL: (888) 653-3333
BRISBANE, CA 94005 FAX: (888) 653-4444 www.okeeffes.com

ALUMINUM SHIPS LADDER
ACCESS TO ROOF HATCH MODEL 523A 60°

_____ **QUANTITY**

MILL FINISH BRONZE ANODIZED
 POWDER COATING CLEAR ANODIZED

SALE NO. _____

DRAWN : _____

DATE : _____

SHEET : _____ **OF** _____